

ELEVATION "B"

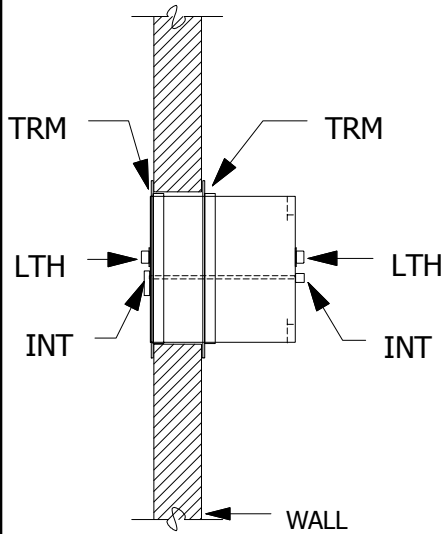

ELEVATION "A"

DOOR NOT SHOWN
TRIM NOT SHOWN

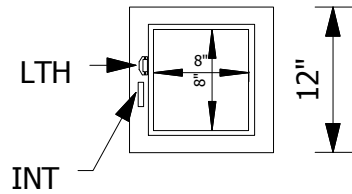

PLAN VIEW

ELEVATION "A"

DOOR SHOWN
TRIM NOT SHOWN

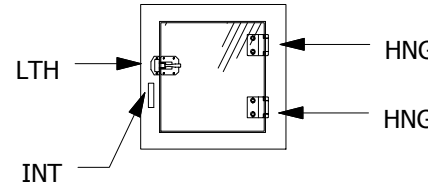

ELEVATION "C"

DOOR SHOWN
TRIM NOT SHOWN

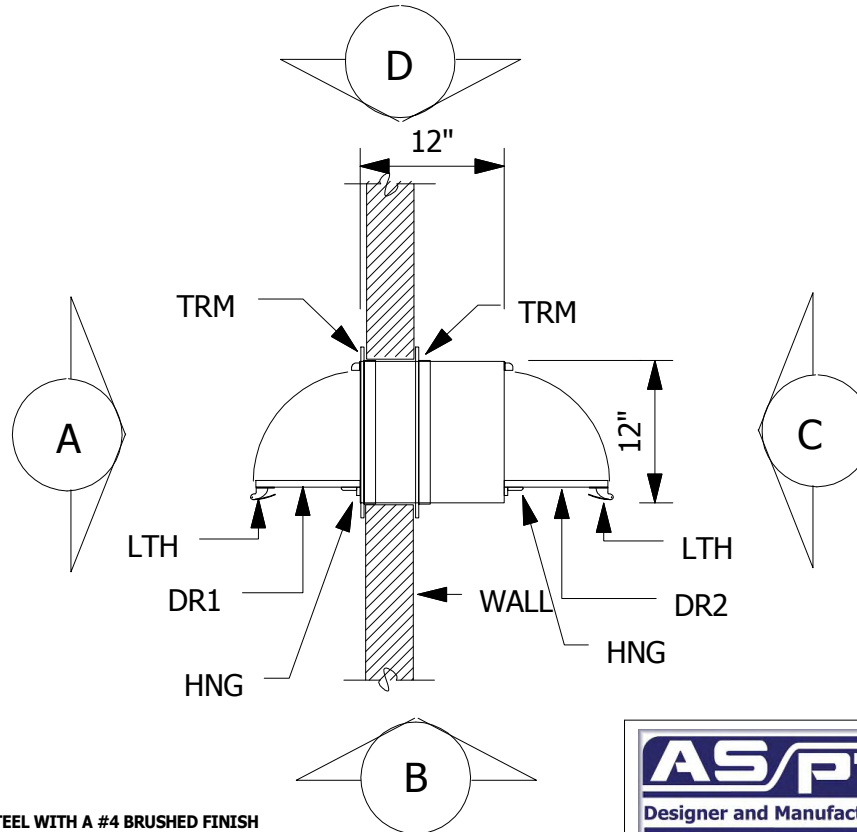
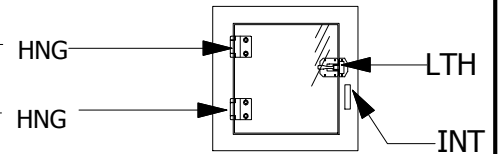

LEGEND

DR1=CLEAR ACRYLIC DOOR
DR2=CLEAR ACRYLIC DOOR
GSK=PEMKO S88W GASKET SEAL
HNG=STAINLESS STEEL DOOR HINGE
INT=POLISHED ALUMINUM INTERLOCK LEVER
LTH=CHROME PLATED SPRING LOADED DOOR CATCH
TRM=1" x 1" 304 STAINLESS STEEL ANGLE

NOTES:

- PASS THRU IS CONSTRUCTED OF A DOUBLE WALL 304 STAINLESS STEEL WITH A #4 BRUSHED FINISH
- TRIM ANGLE IS SHIPPED LOOSE TO ALLOW FLEXIBILITY OF INSTALLATION
- THE PASS THRU HAS MECHANICAL INTERLOCKS
- WALL CUT OUT IS 5/8" LARGER THAN THE OUTSIDE DIMENSIONS OF THE PASS THRU
- THE I.D. DIMENSIONS SHOWN ON THE DRAWING REFLECT THE NET DOOR OPENING.
- ALL SEAMS HAVE A CONTINUOUS WELD AND ARE GROUND SMOOTH TO MATCH THE #4 FINISH



PO Box 427
Rancho Cucamonga, CA 91729-0427
Voice: (800) 913-0054
Fax: (909) 483-1801

Drw# DWS121212

Title: MODEL "SWS" PASS THROUGH

Sheet:

Project name: