

ELEVATION "A"

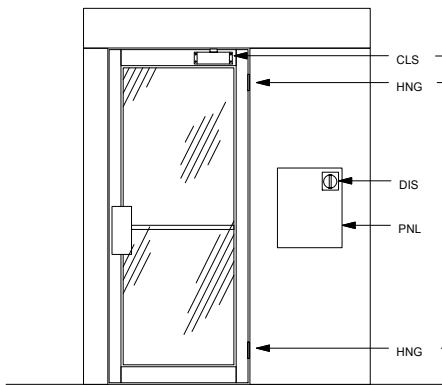

ELEVATION "B"

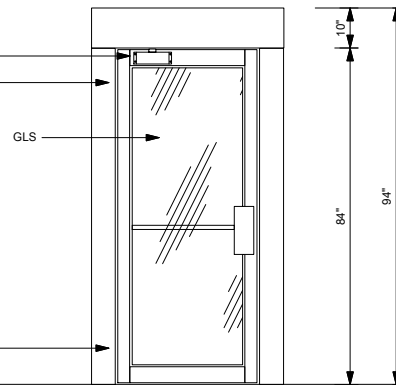

ELEVATION "D"

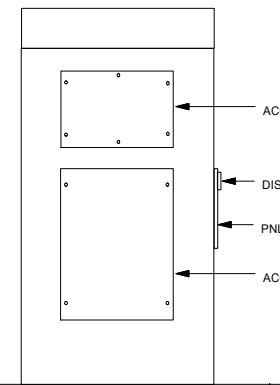

ELEVATION "D" cut away view

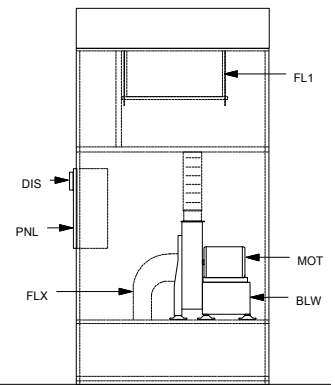

LEGEND
 BLW=5HP DIRECT DRIVE PADDLE WHEEL BLOWER 1550 CFM @ 6" S.P.
 CLS=COMMERCIAL DUTY DOOR CLOSER
 DIS=NON-FUSED DISCONNECT SWITCH FOR CONTROL PANEL
 EMO=EMERGENCY STOP SWITCH
 DR1=CLEAR ANODIZED ALUMINUM FRAME DOOR (ENTRY END)
 DR2=CLEAR ANODIZED ALUMINUM FRAME DOOR (EXIT END)
 FL1=99.99% @ .3 MICRON HEPA FILTER
 FLX=8" DIAMETER FLEX CONNECTION FOR RETURN AIR
 GLS=0.25" THICK CLEAR TEMPERED GLASS
 GRL=RETURN AIR GRILLE
 HNG=4.5" NICKLE PLATED BUTT HINGE
 LGT=LED LIGHT FIXTURE
 MOT=5HP DIRECT DRIVE OPEN DRIP PROOF MOTOR 3500 RPM
 NOZ=0.875" DIAMETER WHITE PLASTIC AIR NOZZLE (30 IN WALLS & 6 IN CEILING)
 PL1=HEPA FILTER PLENUM 0.60" THICK ALUMINUM CONSTRUCTION
 PL2=RETURN AIR PLENUM 0.60" THICK ALUMINUM CONSTRUCTION
 PNL=NEMA 1 ENLOSURE CONTROL PANEL
 PRE=MERV 7 PANEL FILTER
 SLV=SLEEVED PENETRATION THROUGH ROOF FOR INSTALLTION OF SPRINKER
 STP=PEMKO #285CPK DOOR SEALS
 SWP=PEMKO #307AV DOOR SWEEP

Notes:

1. The control panel is recessed in mechanical wall on entry side of air shower.
2. The air shower is shipped knock down into (3) walls, (1) roof and (2) doors.
3. The air shower is supplied with a sleeved penetration through the roof section for installation of a sprinkler head. Sprinkler is by others.
4. The air shower does not have a floor. It uses the existing floor.



PO Box 427
 Rancho Cucamonga, CA 91729-0427
 Voice: (800) 913-0054
 Fax: (909) 483-1801

Drw# LP7248LA	Title: MODEL "LP" AIR SHOWER
Sheet:	Date: